

Differential Pressure Gauges

With Magnetic Piston • Model 700.01

With Magnetic Piston and Separation Diaphragm • Model 700.02

Pressure Gauges

- **Differential pressure measuring ranges**
 Model 700.01: from 0 ... 400 mbar to 0 ... 10 bar
 Model 700.02: from 0 ... 160 mbar to 0 ... 2.5 bar
- **Sturdy and compact system case made of stainless steel**
- **High working pressures (static pressures), optionally 100, 250 or 400 bar (Model 700.02 to 100 bar)**
- **Overpressure safe either side to maximum working pressure (exception for Model 700.02: see table overleaf)**
- **System and/or case of indication may be changed locally**
- **Reed contacts may also be adjusted and retrofitted locally**
- **Panel mounting flange (for Model 700.01) may also be retrofitted locally**
- **Most simple mounting without any additional elements**
- **Optimal price/performance ratio**

General features

Model 700.01 is particularly intended for the monitoring of differential pressures even in the case of high working pressures in gas and air preparation and supply systems.

Model 700.02, the version with a separation diaphragm, is suitable for liquidous media and therefore also for water treatment and supply systems.

This piston-type differential pressure gauge offers special advantages due to its compact modular design. For instance an on-the-spot replacement of measuring system and case of indication is possible in retrospect and the Reed contacts can be retrofitted and adjusted on the spot. A front surface mounting flange may be retrofitted on model 700.01.

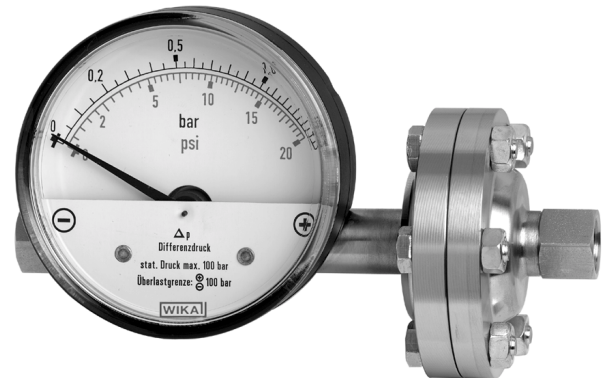
Although these models have a high overload capacity either side up to the maximum working pressure, the weight of the standard versions, i.e. approx. 220 g in the case of model 700.01 and approx. 500 g in the case of model 700.02, is extremely low. Therefore, these gauges provide an economical and flexible solution to your measuring task.

Main applications

- Filter plants
- Monitoring of pumps
- Cooling circuits
- Pipeline systems



Model 700.01

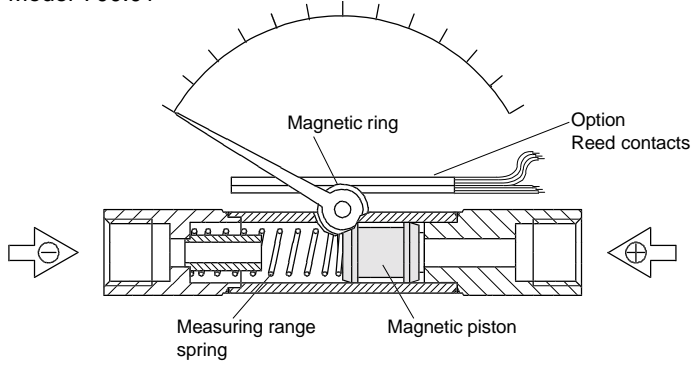


Model 700.02 with separation diaphragm

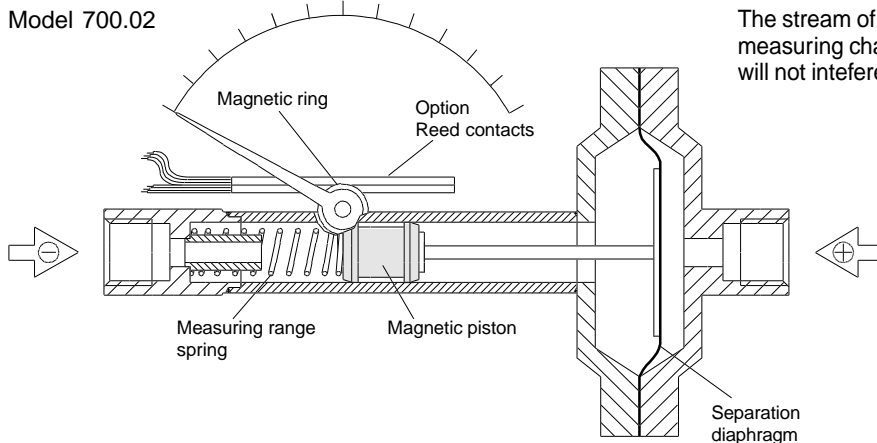


Illustration of operating principle

Model 700.01



Model 700.02



Design and operating principle

Pressure p_1 and p_2 are given in the \oplus and \ominus measuring medium chambers separated by **magnetic piston** under pressure resp. **magnetic piston and separation diaphragm** for Model 700.02.

The difference in pressure causes axial movement (measuring travel) of the piston supported by a **measuring range spring**.

A **magnetic ring** mounted on the instrument pointer follows the magnets movement in the piston so that each piston position is appropriated to a defined pointer position.

This design ensures complete mechanical separation of the measuring system and the case and eliminates external leakage.

The stream of volume from the \oplus measuring chamber to the \ominus measuring chamber is minimized by the constructive design and will not interfere with the process (only for Model 700.01).

For applications where liquids or dirty and heavily contaminated media are to be measured the version with a **separation diaphragm** Model 700.02, is suitable (no volume flow from \oplus to \ominus media chamber).

Pressure entries identified \oplus and \ominus ,
 \oplus high pressure, \ominus low pressure
 Mounting by means of

- rigid tailpipes,
- panel mounting (optional extra) or
- device for surface mounting (optional extra)

Technical data	Model 700.01	Model 700.02
Nominal size	80 mm	
Accuracy	accuracy $\pm 3\%$ full scale ascending	accuracy $\pm 5\%$ full scale ascending
Scale ranges	0 ... 400 mbar to 0 ... 10 bar	0 ... 160 mbar to 0 ... 2.5 bar
Working pressure max. (static pressure)	optionally 100, 250 or 400 bar	100 bar (scale ranges 0 ... 160 mbar and 0 ... 250 mbar: 50 bar)
Overpressure safety	either side to maximum working pressure (exception for Model 700.02, scale ranges 0 ... 160 mbar and 0 ... 250 mbar: overpressure safety up to 50 bar)	
Operating temperature Ambient Medium	0 ... +60 °C +100 °C maximum	
Degree of protection	IP 54 (EN 60 529 / IEC 529)	
Pressure chamber with connections (exposed to pressure medium)	stainless steel 1.4571, 2 x G 1/4 female, entry on the right and left, in-line (EN 837-1 / 7.3)	
Pressure element (exposed to pressure medium)	compression spring, stainless steel 1.4310	
Magnetic piston (exposed to pressure medium)	piston: stainless steel 1.4571 magnet: hard-ferrit	
Separation diaphragm (exposed to pressure medium)	-	NBR
Dial	white aluminum with dual scale: outer scale black (bar), inner red (psi)	
Pointer	black aluminum	
Case of indication	black aluminium, die-casting	
Window	acrylic plastic, snap-fit window	

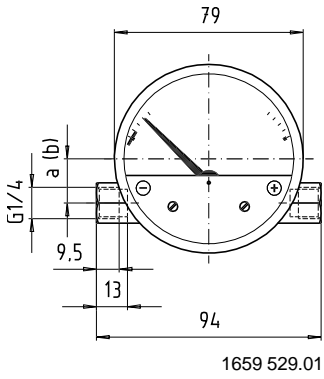
Optional extras

- Other threaded pressure connection female or male
- Bottom or back pressure entry, \oplus connection left
- Fine strainer integrated in \oplus connection
- Resettable max. drag pointer

Following accessories may be retrofitted locally:

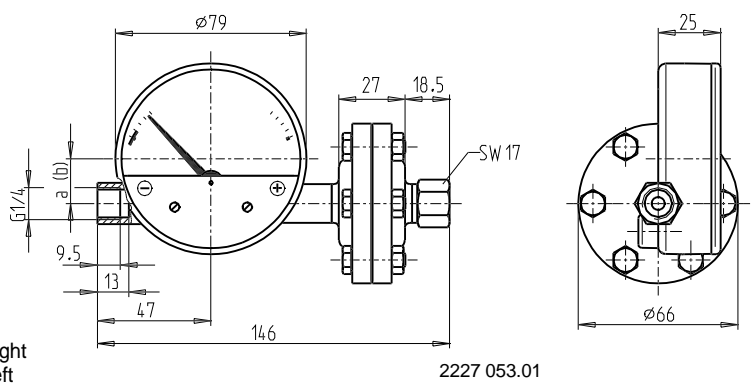
- Reed contacts, single or double change over contact, adjustable from the outside
- Panel mounting flange (only for Model 700.01)
- Device for surface mounting

Dimensions Standard version
Model 700.01

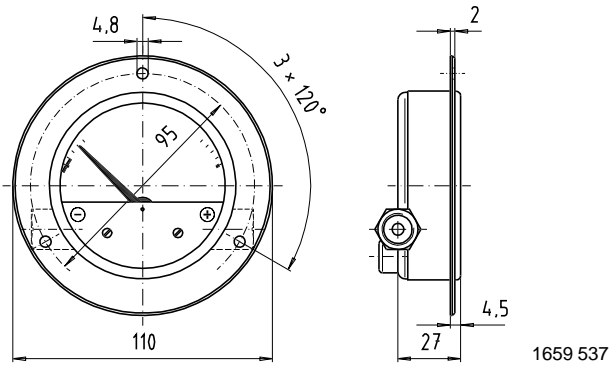


a = 18,5 ⊕ connection right
b = 2,5 ⊕ connection left

Model 700.02

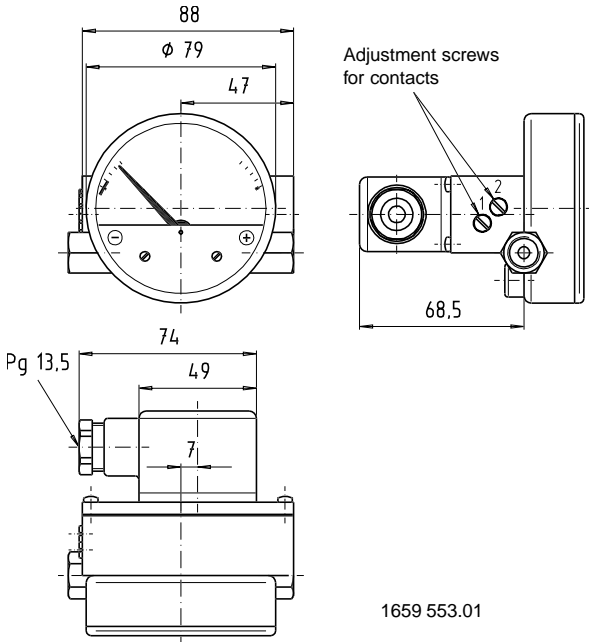


Optional version Panel mounting flange (only for Model 700.01)

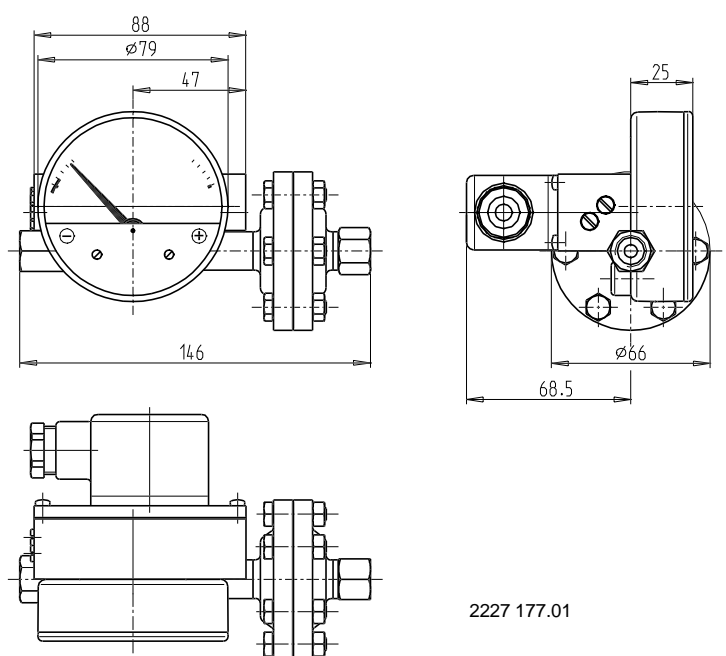


Optional version Reed contacts (single and/or double change over contact)

Model 700.01



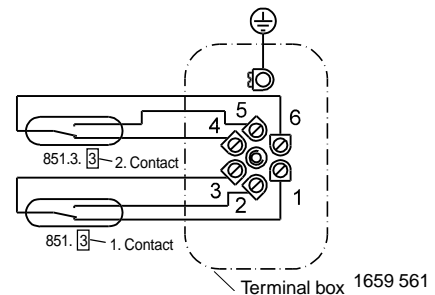
Model 700.02



Electric wiring diagram and technical data
Reed contact model 851.3 or 851.33:

Especially conceived to allow low current circuits to be switched directly, switch point may be set by means of adjusting screws from the exterior in a range of 10 ... 100 % of full scale value.

Max. switching voltage: 250 VDC / VAC 30 VDC / VAC
Max. load: 60 W 3 W
Max. strength of current: 1 A 0.2 A
Switching hysteresis: 5 % of full scale value



Ordering information for differential pressure gauges with magnetic piston Model 700.01/700.02

Field No.	Code	Features	
Separation diaphragm			
1	1	without <i>Model 700.01</i>	
	2	with <i>Model 700.02, Diaphragm material NBR</i>	
Unit			
2	G	dual scale bar/psi (black/red) <i>standard</i>	
	?	other <i>Please state as additional text</i>	
Range			
3	AM	0 ... 0.16 bar 2nd scale psi red <i>only for Model 700.02 stat. 50 bar / overpressure 50 bar</i>	
	AN	0 ... 0.25 bar 2nd scale psi red <i>only for Model 700.02 stat. 50 bar / overpressure 50 bar</i>	
	BB	0 ... 0.4 bar 2nd scale psi red	
	BC	0 ... 0.6 bar 2nd scale psi red	
	BD	0 ... 1 bar 2nd scale psi red	
	BE	0 ... 1.6 bar 2nd scale psi red	
	BF	0 ... 2.5 bar 2nd scale psi red	
	BG	0 ... 4 bar 2nd scale psi red <i>only for Model 700.01</i>	
	BH	0 ... 6 bar 2nd scale psi red <i>only for Model 700.01</i>	
	BI	0 ... 10 bar 2nd scale psi red <i>only for Model 700.01</i>	
??	other <i>Please state as additional text</i>		
Process connection			
4	AA	2 x G 1/4 female <i>standard</i>	
	AH	2 x 1/4 NPT female	
	AL	2 x G 1/4 B with stainless steel connection pieces	
	AB	2 x G 1/2 B with stainless steel connection pieces	
	AK	2 x 1/2 NPT female with stainless steel connection pieces	
	??	other <i>Please state as additional text</i>	
Connector position			
5	K	+ right/ - left horizontal in-line (side by side) <i>standard</i>	
	T	+ left/ - right horizontal in-line (side by side)	
	?	other <i>Please state as additional text</i>	
Overpressure safety / working pressure max.			
6	H	PN 100 bar <i>standard</i>	
	F	PN 250 bar <i>only for Model 700.01</i>	
	V	PN 400 bar <i>only for Model 700.01</i>	
Fine strainer			
7	Z	without <i>standard</i>	
	J	integrated in + connection	
Mounting device			
8	Z	without <i>standard</i>	
	D	panel mounting flange, black steel <i>only for Model 700.01</i>	
	W	device for surface mounting	
Set / drag pointer			
9	Z	without <i>standard</i>	
	K	adjustable red maximum drag pointer on acrylic window	
Alarm contacts			
10	Z	without <i>standard</i>	
	1	1 SPDT reed contact 851.3 30V	
	2	1 SPDT reed contact 851.3 250V	
	3	2 SPDT reed contact 851.3 .3 30V	
	4	2 SPDT reed contact 851.3 .3 250V	
Wiring			
11	Z	without <i>standard</i>	
	P	terminal box <i>standard for alarm contacts</i>	
	1	other <i>Please state as additional text</i>	
Additional order info			
12	YES	NO	
	1	Z	quality certificates <i>Please state in clearly understandable text !</i>
13	T	Z	additional text <i>Please state in clearly understandable text !</i>

Order code for Model 700.01 and 700.02

1	2	3	4	5	6	7	8	9	10	11	12	13
700.0	-D	-	-	-	-	-	-	-	-	-	-	-

Additional text: _____

Specifications and dimensions given in this leaflet represent the state of engineering at the time of printing. Modifications may take place and materials specified may be replaced by others without prior notice.



WIKA Alexander Wiegand GmbH & Co. KG
 Alexander-Wiegand-Straße · 63911 Klingenberg
 Tel.: (0 93 72) 132-0 · Fax: (0 93 72) 132-406
 http://www.wika.de · E-mail: info@wika.de

